



AXL - 100

Sealed, maintenance free, lead-acid **ACUMAX®** batteries with **over 12** years designed lifetime are made in **AGM** technology - electrolyte is absorbed in highly porous fiber glass separators placed between the plates. They use a gas recombination cycle which prevents electrolyte loss and allows the batteries to be used in rooms without forced ventilation, that are occupied by people. One-way, self-regulating pressure relief valves prevent the case from blowing up, by preventing excessive buildup of pressure in the cells.

- GSM base stations
- emergency lighting systems
- wind turbines
- solar systems

Main applications

- Uninterruptible Power Supplies (UPS)
- telecommunication PABX
- substations

Technical data

Nominal voltage	2 V
Nominal capacity	100 Ah/ C ₁₀
Design life	10 - 12 years @ 25°C over 12 years @ 20°C according to Eurobat, Long Life group
Weight	~ 6.0 kg
Dimensions	
Height	212 mm
Length	170 mm
Width	72 mm
Internal resistance	≤ 1.4 mΩ
Charging voltage @ 25°C	
Standby use	2.275 V ± 0.03 V
Cykle use	2.45 V ± 0.05 V
Charging current	
Recommended	10 A
Maximum	30 A
Max. discharge current (5s)	800 A
Container material	
Standard	ABS UL 94-HB
Optional (Flame-retardant)	ABS UL 94-V0

Battery approved for transportation by air, sea or land. Classified as non-hazardous material: *IATA/ICAO Special Provision A67, DOT-CFR Title 49 parts 171-189, IMDG amendment 27.*

Discharge characteristics

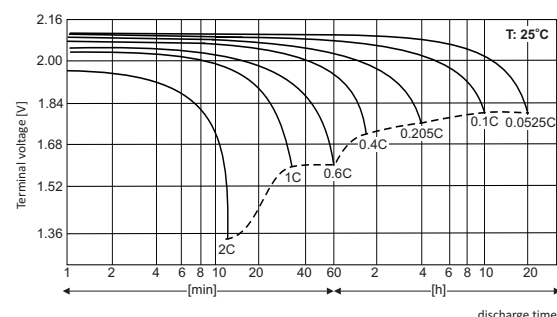

Dimensions

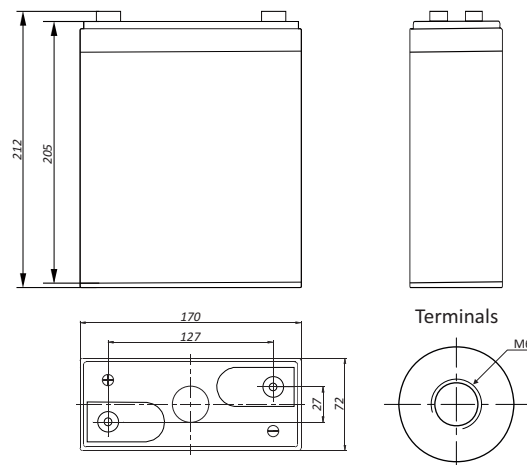

Tolerance: +/- 2mm;

Constant current discharge (Current [A], 25 [°C] / 77 [°F])

U _f [V/cell]	Discharge time												
	15 min	20 min	30min	45min	1h	2h	3h	4h	5h	6h	8h	10h	20h
1,85	103,0	92,7	76,7	60,8	49,9	30,0	23,2	19,0	16,2	14,2	11,4	9,55	5,07
1,80	117,0	103,2	82,3	64,0	53,0	31,6	24,3	19,9	16,9	14,8	11,8	10,0	5,25
1,75	128,5	111,2	87,1	67,3	55,3	32,9	25,2	20,6	17,4	15,1	12,1	10,1	5,30

Constant power discharge (Power [W/cell], 25 [°C] / 77 [°F])

U _f [V/cell]	Discharge time												
	15 min	20 min	30min	45min	1h	2h	3h	4h	5h	6h	8h	10h	20h
1,80	218,7	194,2	156,0	122,2	101,9	61,2	47,3	38,8	33,1	29,1	23,4	19,9	10,4
1,75	236,9	207,0	163,9	127,7	105,9	63,5	48,9	40,0	34,0	29,7	23,8	20,0	10,5
1,70	250,2	219,4	170,5	131,6	109,0	65,1	50,0	40,7	34,5	30,2	24,2	20,2	10,6

U_f - Final voltage

