

ACUMAX® sealed maintenance-free lead-acid battery AV series



AV 9-12

- uninterruptible power supplies
- telecommunication PABX
- cash registers and fiscal printers
- emergency lighting systems
- fire and security systems
- solar powered systems
- mobile and portable equipment
- lawn mowers, electrical bicycle

Technical data

Nominal voltage	12 V
Nominal capacity	9 Ah/ C ₂₀
Design life	5 years @ 25°C 6 - 9 years @ 20°C according to Eurobat, General Purpose group
Weight	~ 2.7 kg
Dimensions	
Height	102 mm
Length	151 mm
Width	65 mm
Internal resistance	≤ 14 mΩ
Charging voltage @ 25°C	
Standby use	13.65 V ± 0.18 V
Cycle use	14.70 V ± 0.30 V
Charging current	
Recommended	0.9 A
Maximum	2.7 A
Max. discharge current (5s)	135 A
Container material	
Standard	ABS UL 94-HB
Optional (Flame-retardant)	ABS UL 94-V0

Battery approved for transportation by air, sea or land. Classified as non-hazardous material: *IATA/ICAO Special Provision A67, DOT-CFR Title 49 parts 171-189, IMDG amendment 27.*

Constant current discharge (Current [A], 25 [°C] / 77 [°F])

U _k [V/cell]	Discharge time										
	5 min	10 min	15 min	30 min	1h	2h	3h	4h	5h	10h	20h
1,80	32,6	20,4	14,9	8,45	5,29	2,72	2,18	1,74	1,51	0,841	0,442
1,75	35,0	21,9	15,8	6,93	5,37	2,78	2,23	1,77	1,53	0,855	0,451
1,70	36,7	22,9	16,5	9,35	5,45	2,84	2,27	1,80	1,55	0,866	0,456

Constant power discharge (Power [W/cell], 25 [°C] / 77 [°F])

U _k [V/cell]	Discharge time										
	5 min	10 min	15 min	30 min	1h	2h	3h	4h	5h	10h	20h
1,75	64,7	42,0	32,3	17,0	10,7	5,69	4,49	3,63	3,05	1,71	0,902
1,70	67,8	44,0	33,4	17,7	11,0	5,82	4,62	3,73	3,10	1,75	0,907
1,65	71,2	46,1	34,7	18,0	11,3	5,90	4,75	3,85	3,15	1,78	0,913

U_f - Final voltage



Main applications

- medical equipment
- fishing lights
- parking meters
- toys

Discharge characteristics

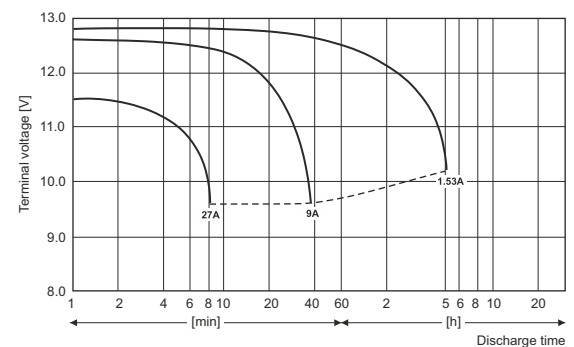

Dimensions

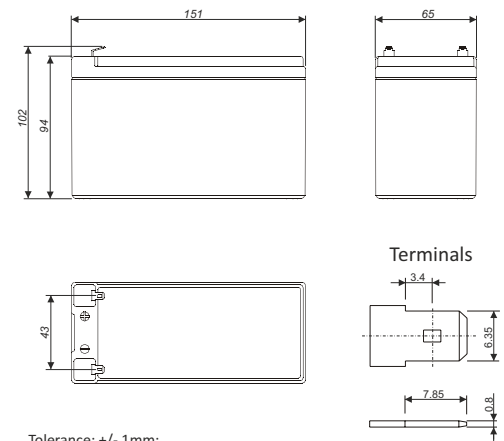

Tolerance: +/- 1mm;