



AMG 31-12

AMG series batteries made in **GEL technology** are designed for standby use (emergency power supply) as well as hard condition cycle use like large number of cycles, deep discharge and high temperature. The cycle life of AMG series batteries reaches **600 cycles** for 80% depth of discharge. One-way, self regulating pressure relief valves prevent the case from blowing up, by preventing excessive buildup of pressure in the cells.

- boats, yachts
- emergency lighting systems
- traction
- wind turbines
- electric vehicles
- solar powered systems
- wheelchairs, golf-carts
- cable TV

Main applications

- uninterruptible power supplies (UPS)
- telecommunication PABX
- power station

Technical data

Nominal voltage	12 V
Nominal capacity	30 Ah/ C <sub>20</sub>
Design life	8 years @ 25°C 10-12 years @ 20°C according to Eurobat, High Performance group
Weight	~ 10.7 kg
Dimensions	
Height	167 mm
Lenght	195 mm
Width	130 mm
Internal resistance	≤ 14.6 mΩ
Charging voltage @ 25°C	
Standby use	13.65 V ± 0.15 V
Cycle use	14.70 V ± 0.30 V
Charging current	
Recommended	3.0 A
Maximum	7.5 A
Max. discharge current (for 5 sec)	300 A
Container type	
Standard	ABS UL 94-HB
Fire retardant (optional)	ABS UL 94-V0

Not restricted for air, surface and water transport. Classified as non-hazardous material (IATA/ICAO Special Provision A67, DOT-CFR Title 49 parts 171-189, IMDG amendment 27).

Discharge characteristics graph

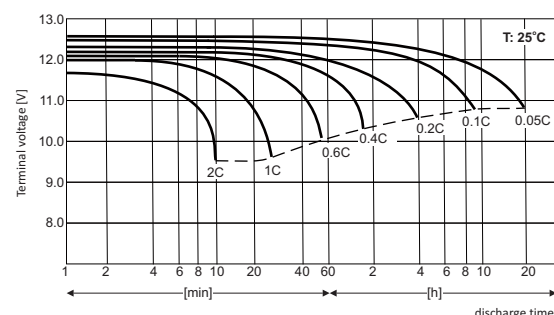

Dimensions

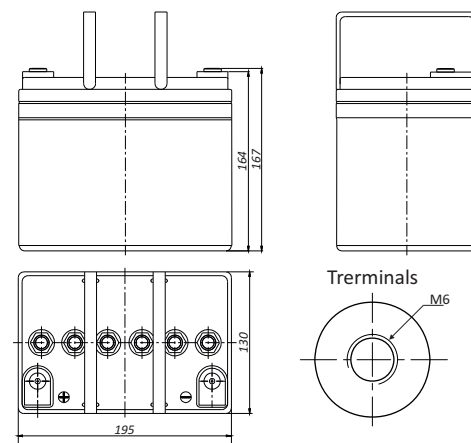

Tolerance: +/- 2mm;

Constant current discharge table (Current [A], 25 [°C])

F.V. [V/cell]	Discharge time													
	20 min	30 min	45 min	1h	2h	3h	4h	5h	6h	7h	8h	9h	10h	20h
1,80	29,1	22,3	16,8	14,6	8,73	6,59	5,40	4,62	3,99	3,52	3,18	2,91	2,65	1,50
1,75	32,7	24,5	18,1	15,6	9,26	6,96	5,66	4,80	4,13	3,64	3,28	3,00	2,70	1,53
1,70	35,2	26,2	19,2	16,5	9,81	7,25	5,84	4,95	4,27	3,76	3,38	3,08	2,76	1,55

Constant power discharge table (Power [W/cell], 25 [°C])

F.V. [V/cell]	Discharge time													
	20 min	30 min	45 min	1h	2h	3h	4h	5h	6h	7h	8h	9h	10h	20h
1,75	61,0	46,3	34,6	30,0	17,9	13,6	11,0	9,41	8,12	7,19	6,49	5,96	5,37	3,05
1,70	65,0	49,2	36,5	31,6	18,9	14,1	11,4	9,68	8,39	7,42	6,67	6,11	5,49	3,08
1,67	66,9	50,5	37,5	32,6	19,3	14,5	11,6	9,85	8,50	7,50	6,76	6,17	5,54	3,11

F.V. - Final voltage

